

# moVo

evolution

User Guide



# BROME

# TABLE OF CONTENTS

<b>1. INTRODUCTION .....</b>	<b>3</b>
<b>2. IMPORTANT PRECAUTIONS .....</b>	<b>4</b>
- BEFORE DRIVING THE SCOOTER - pg. 4	
- CAUTIONS WHEN DRIVING - pg. 5	
- GENERAL SAFETY INFORMATION - pg. 6	
- CAUTION WHEN DRIVING ON INCLINES- pg. 6	
- CAUTION WHEN CLIMBING- pg. 7	
- ELECTROMAGNETIC INTERFERENCE AND WARNINGS - pg. 7	
<b>3. PRODUCT OVERVIEW .....</b>	<b>9</b>
- THE SCOOTER - pg. 9	
- IDENTIFICATION OF CONTROL PANEL - pg. 10	
<b>4. OPERATING YOUR SCOOTER .....</b>	<b>11</b>
- FREE-WHEELING (N-D LEVER) - pg.13	
- FIXED HOOKS - pg. 13	
- DISASSEMBLING YOUR SCOOTER - pg. 13	
- DISASSEMBLING BATTERIES - pg. 14	
<b>5. BATTERY GAUGE AND CHARGER .....</b>	<b>14</b>
- BATTERY GAUGE - pg.14	
- OPERATING THE CHARGER - pg. 15	
- INFORMATION FOR BATTERY & CHARGER - pg. 16	
<b>6. CARE AND MAINTENANCE.....</b>	<b>17</b>
- DAILY CHECK - pg. 17	
- WEEKLY CHECK - pg. 17	
- MONTHLY CHECK - pg. 18	
- CLEANING YOUR SCOOTER - pg. 18	
- MAINTENANCE - pg. 19	
<b>7. OTHER INFORMATION .....</b>	<b>20</b>
- RECYCLING & DISPOSAL - pg. 20	
- SERVICE LIFE - pg. 20	
<b>8. TROUBLE SHOOTING .....</b>	<b>20</b>
- SCOOTER WON'T MOVE WHEN KEY IN TURNED ON - pg. 20	
- ERROR CODE - pg. 21	
- OTHER PROBLEMS - pg. 21	
<b>9. TECHNICAL SPECIFICATIONS .....</b>	<b>22</b>
<b>10. WARRANTY .....</b>	<b>23</b>

## INTRODUCTION

**Thank you and congratulations on purchasing your new MOVO Mobility Scooter. It is designed to provide you with transportation ability indoors and outdoors.**

We pride ourselves on providing safe and comfortable products. Our goal is to ensure your complete satisfaction with our product.

Please read and observe all warning and instruction provided in the owner's manual before operating this scooter. Also, retain this booklet for future reference.

In case of a serious incident with the product, you should inform the manufacturer and the competent authority in your country.

**If you have any questions, you can contact:**



[info@moevolution.com](mailto:info@moevolution.com)  
Tél.: 1-888-480-MOVO (6686)

**Granby, Québec**  
Canada

# IMPORTANT PRECAUTIONS

## 1. BEFORE DRIVING THE SCOOTER

- Before taking the first trip with mobility scooter, you should familiarize yourself well the operation of mobility scooter and with the operation elements. Please take your timeto read this introduction booklet.
- Before driving, please evaluate the personal condition, and fully understand the operationof mobility scooter.
- You should not assemble, maintain, and operate the mobility scooter before you read this instruction booklet.
- Observe and obey all pedestrian rules and regulations in which you are riding.
- Mobility device may only be used on the traffic routes for which it is approved in accordancewith the relevant national legislation.
- Always be aware of pedestrians and situations which might require extra care when using your scooter on public walk ways and footpaths.
- Do not drive your scooter if you are under the influence of alcohol or medication that may affect your ability.
- Try not to drive scooter at night.
- Turn the key off before getting on or off. (see section 4-1 General Operation)



Please observe all relevant rules and regulations pertaining to pedestrians and road users, at all times when you are driving the scooter.



- Do not turn the power on before you get in and sit securely on the seat.
- Be certain that the power is turned off when get in, get out. This will eliminatethe possibility of accidentally activating the wigwag controls and causing injury.
- Keep your weight toward the middle of the deck. Putting most or all of yourweight on the edge of the deck may cause an unstable condition.
- Only one person at a time could ride a MOVO Mobility Scooter. Do not carrypassengers under any circumstances.

### Practical Tips :

- If you are new to drive a scooter, it is a good idea to practice in a clear, safe space ona sound level surface. (I.e. Park, Playground).
- Basic functions to practice: Wig wag accelerate /Wig wag release /Stop /Reverse /Turn /Ramp proceeding.
- Set the speed control to its lowest speed, slightly increase the speed when you are getting familiar with the scooter. (see section 4-1 for speed Dial Knob)

## 2. CAUTIONS WHEN DRIVING

- Please do the daily check before your journey always. (Refer to 6-1 Daily check.)
- Do not extend your body over the mobility scooter.
- Please make sure your safety when crossing the level crossing.
- When crossing the level crossing, please be aware of the wheel and rail are perpendicular.
- Do not use the mobile phone and wireless mobile devices.
- Do not use the batteries of mobility scooter to charge any other electric devices, except the accessories from original manufacturer.
- Do not drive on a slope which is over the limit. (Refer to 2-4 Caution When Driving)
- Reduce speed when descending to prevent any danger. Increase speed when ascending
- Do not drive to across the obstacle over the limit (Refer to 2-5 Caution When Climbing)
- Do not attempt to drive the scooter in rain, wet grass, or any other potentially hazardous condition.
- Ensure that the lights of scooter are turned on while driving at night or in poor visibility.
- Please stop operating the scooter if the batteries have drained, continuous operation may damage the scooter.



- Always follow the local pedestrian traffic rules when riding outside.
- When turning, reduce your speed and maintain a stable center of gravity. This greatly reduces the possibility of a tip or fall.

- Do not turn off the power while driving.
- Do not stretch your body out on the scooter. For maximum stability, lean forward in your body while proceeding up ramps, inclines, curbs, or any low rise.
- Do not attempt to have your scooter climb or descend an obstacle that is inordinately high. This may cause the scooter to tip.
- Do not attempt to use your scooter on an escalator.
- Do not make sharp turns while driving. This may cause the scooter to tip.
- Never place the scooter in freewheel mode when on any sort of an incline or decline. When the scooter is parked, the lever for engaging and disengaging the motors must be locked firmly into the "DRIVE" position.
- Cross the railroad crossing, make sure the wheels pass the rail at 90 degree angles, avoid scooter stuck on railroad.
- When descending an incline, use the slowest speed possible. If the descent is faster than you desire, release the throttle lever to stop the scooter. Then press the throttle lever slightly to control the speed.

### 3. GENERAL SAFETY INFORMATION FOR SCOOTER

- Batteries should be fully charged before using for maximum performance and longevity. (see section 5-2)
- The maximum load of the scooter is 136KG . Do not exceed the maximum permissible load. Exceeding the max.weight rating may result in injury to yourself.
- The maximum load of the front basket is 3KG, exceeding the max. weight may result damage to basket.
- The mobility device is only designed for use by a single occupant whose maximum weight does not exceed the maximum permissible load of the device. Never use the mobility device to transport more than one person (including children).
- Do not attempt to carry out maintenance work that is not described in this user manual.
- Do not change, modify, remove any parts from products especially safety protected parts such as anti-tips.
- Completely deflate the tires (air tires) before dismantling the rim or attempting



• Materials and assemblies of scooter is flame resistant.

Avoid exposure the scooter to rain, snow, ice, salt, or standing water whenever possible. Maintain and store in a clean and dry condition. Any direct contact with water can cause damage to the scooter and electrical system.

- Do not remove the anti-tip wheels or modify your scooter in any way that is not authorized.
- Only use the chargers, accessories, or components supplied as original equipment with your scooter supplier.
- Immediately stop using the scooter if you encounter a problem with scooter. Turn off the power and contact dealer for further checking.
- Please pay more attention when driving the scooter, the emergency stop may encounter.

### 4. CAUTIONS WHEN DRIVING ON INCLINES

- The scooter has been rated to a maximum climbable height, obstacle height, and gap. (Refer to 9 Section Specifications)
- Never drive on a slope that exceeds the rated slope.
- The weight capacity limit at different ramp degree (please refer to following picture).

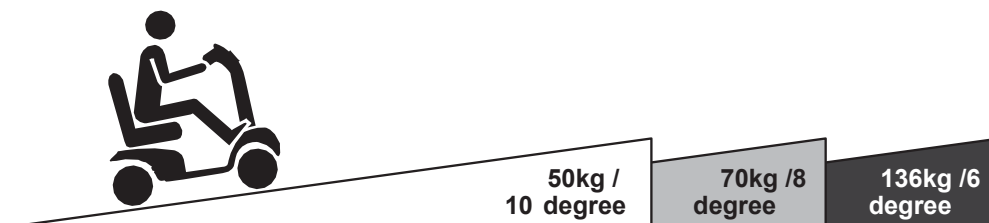

- Your scooter's ability to travel up inclines is affected by your weight, your scooter's speed, your angle of approach to the incline, and your scooter setup.
- Please avoid to drive on a long ramp or any uneven terrain to prevent any danger from motor defected.
- The batteries voltage normally will go up when driving on descending road. If the battery voltage becomes too high, the over-voltage protection will be activated by slowing the speed till the scooter stops. (error code :ERR3 will be displaying). Please pull over the scooter to the safe area, release the wigwags and restart the scooter again.

## 5. CAUTIONS WHEN CLIMBING

- The maximum height of obstacle and curb that scooter can climb is up to 7 cm (A).
- The maximum gap that scooter can drive over is 17 cm (B).
- When driving scooter on ramp, adjust body center of gravity for scooter stability.



Even though your scooter has been rated with maximum climbable, we suggest not to drive through an obstacle which is higher than 7 cm.

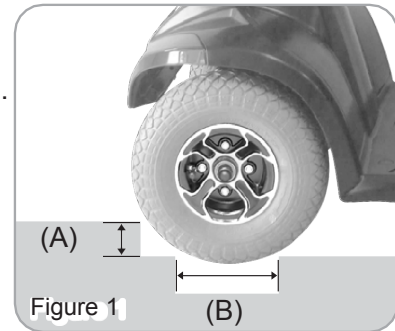

Figure 1

## 6. ELECTROMAGNETIC INTERFERENCE AND WARNINGS



It is very important that you read this information regarding the possible effects of Electromagnetic Interference on your mobility scooter.

Mobility scooters may be susceptible to electromagnetic interference (EMI), which is interfering electromagnetic energy (EM) emitted from sources such as radio stations, TV stations, amateur radio (HAM) transmitters, two-way radios, and mobile phones. The interference (from radio wave sources) can cause the mobility scooter to release its brakes, move by itself, or move in unintended directions. It can also permanently damage the mobility scooter control system. The intensity of the interfering EM energy can be measured in volts per meter (V/m). Each mobility scooter can resist EMI up to certain intensity. This is called its "immunity level." The higher the immunity level, the greater the protection. At this time, current technology is capable of achieving at least a 20 V/m immunity level, which would provide useful protection from the more common sources of radiated EMI. The immunity level of this mobility scooter model is not known.

There are a number of sources of relatively intense electromagnetic fields in the everyday environment. Some of these sources are obvious and easy to avoid. Others are not apparent and exposure is unavoidable. However, we believe that by following the warnings listed below, your risk to EMI will be minimized.

**The sources of radiated EMI can be broadly classified into three types :**

1. Hand-held portable transceivers (transmitters-receivers) with the antenna mounted directly on the transmitting unit. Examples include: citizens band (CB) radios, "walkie talkie," security, fire, and police transceivers, mobile phones, and other personal communication devices.



Some mobile phones and similar devices transmit signals while they are ON, even when not being used

2. Medium-range mobile transceivers, such as those used in police cars, fire trucks, ambulances, and taxis. These usually have the antenna mounted on the outside of the vehicle; and

3. Long-range transmitters and transceivers such as commercial broadcast transmitters (radio and TV broadcast antenna towers) and amateur (HAM) radios. diffusion commerciale (pylônes d'antenne de diffusion radio et TV) et les radios amateurs.



Other types of hand-held devices, such as cordless phones, laptop computers, AM/FM radios, TV sets, CD players, and cassette players, and small appliances, such as electric shavers and hair dryers, so far as we know, are not likely to cause EMI problems to your mobility scooter.

#### **Mobility Scooter Electromagnetic Interference:**

Because EM energy rapidly becomes more intense as one move closer to the transmitting antenna (source), the EM fields from hand-held radio wave sources (transceivers) are of special concern. It is possible to unintentionally bring high levels of EM energy very close to the motorized scooter control system while using these devices. This can affect mobility scooter movement and braking. Therefore, the warnings listed below are recommended to prevent possible interference with the control system of the mobility scooter.

#### **Warnings:**

Electromagnetic interference (EMI) from sources such as radio and TV stations, amateur radio (HAM) transmitters, two-way radios, and mobile phones can affect mobility scooters. Following the warnings listed below should reduce the chance of unintended brake release or mobility scooter movement which could result in serious injury.

1. Do not operate hand-held transceivers (transmitters-receivers), such as citizens band (CB) radios, or turn ON personal communication devices, such as mobile phones, while the mobility scooter is turned ON;
2. Be aware of nearby transmitters, such as radio or TV stations, and try to avoid coming close to them;
3. If unintended movement or brake release occurs, turn the mobility scooter OFF as soon as it is safe;
4. Be aware that adding accessories or components, or modifying the mobility scooter, may make it more susceptible to EMI; and
5. Report all incidents of unintended movement or brake release to the distributor listed on the inside front cover of this manual. Note whether there is a source of EMI nearby.



**Important Information:**

1.20 volts per meter (V/m) is a generally achievable and useful immunity level against EMI (as of May 1994). The higher the level, the greater the protection.

2.The immunity level of this product is at least 20V/m.

## PRODUCT OVERVIEW

### 1. THE SCOOTER

Before attempting to drive this scooter on your own, it is important that you familiarize yourself with the controls, and how to operate them.

**Intended use :** The Movo Mobility Scooters provide a means by which a disabled occupant i.e. a disabled person or a person not having the full capacity to walk unaided to have mobility and the freedom to travel.

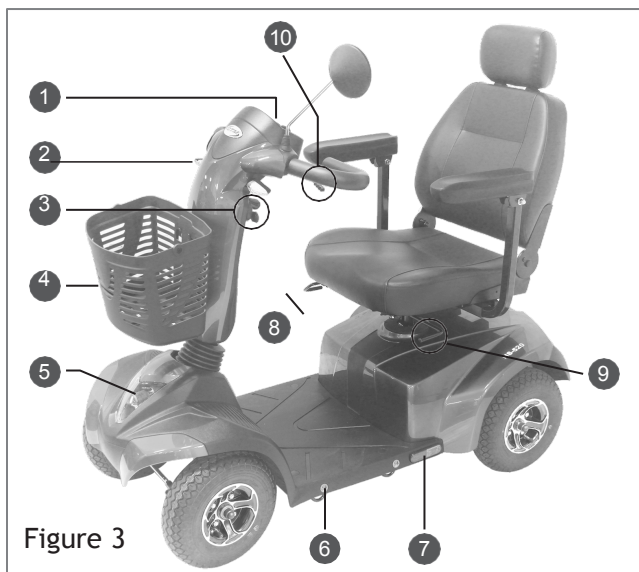

Figure 3

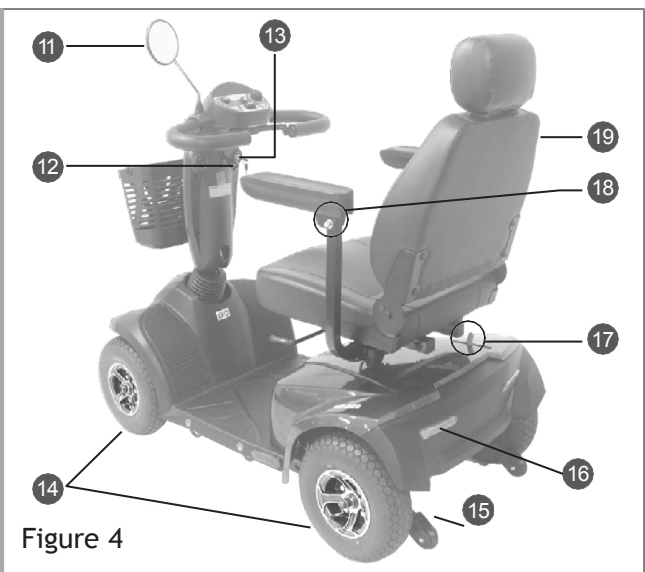

Figure 4

NO	ITEM	NO	ITEM
01	Control Panel	11	Rear Mirror
02	Front Turning Signal	12	Tiller Angle Adjustment
03	Charging Port	13	Key Switch
04	Front Basket	14	Front / Rear Wheels
05	Headlight	15	Anti-Tipper
06	Tie-down Hook	16	Tail light / Rear Turning Signal / Brake Light
07	Reflector		

08	Seat Fore-Aft Adjustment Lever	17	N-D Lever
09	Seat Swivel Lever	18	Adjustable Armrest (Width)
10	Throttle	19	Captain Seat

**2. IDENTIFICATION OF CONTROL PANEL**

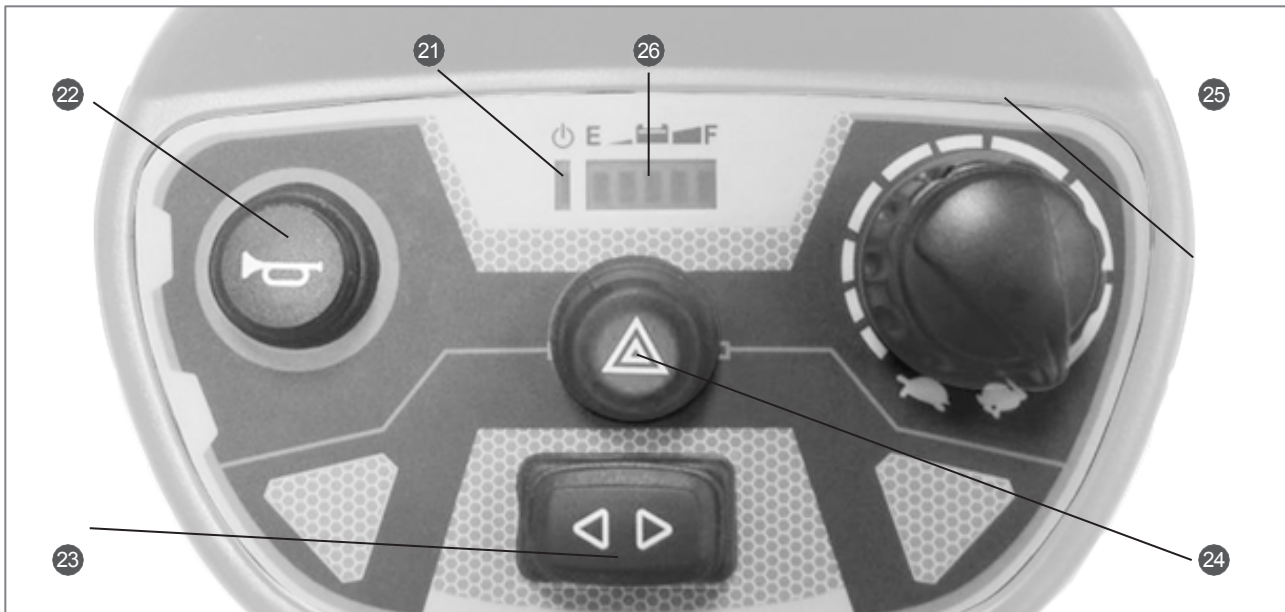



Figure 5 - Brome Control Panel

NO.	ITEM	FUNCTION
21	Power/Self-Diagnostic Warning light	Power on / Error code
22	Horn	Press for warning sound
23	Left /Right Turning Signal	Switch on for left/ right turn
24	Hazard Signal	Press for Hazard on
25	Speed Dial Knob	Adjust the scooter speed
26	Battery Gauge	Battery charge display

# OPERATING YOUR SCOOTER

## Main Key Switch / Headlight :

- Turn the key to the right - Turn scooter on. (Figure 6)
- Turn the key to the left - Turn scooter off
- By turning the key to [  ] to turn on the head light.

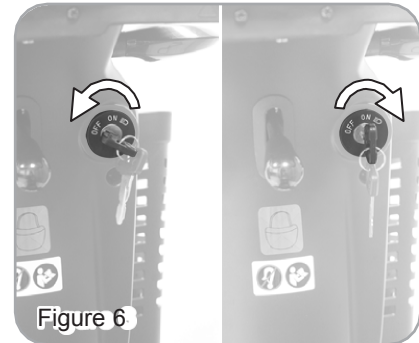

Figure 6



- Always ensure that the scooter is switched off before getting on or off the scooter and before removing any items of the scooter
- Turning the scooter OFF whilst driving will bring the scooter to an abrupt stop and danger.

## Sleep Mode :

- Scooter will go into Sleep Mode with one long beep warning sound if no throttle activity is detected for programmable time period. (Default programmable time is 30 mins.)
- When scooter is in Sleep Mode, the Power/Self-Diagnostic warning light on the control panel will be off, and the scooter will not respond to commands.
- To wake up the scooter, turn the power (key) off and then on again.

## Speed Dial Knob :

The Rabbit means fast and Turtle means slow.

- The dial knob allows you to adjust the speed of you scooter. (Figure 7)



Do not set the speed at maximum when operating the scooter. Adjust the speed at maximum when inclining a slope, and adjust to minimum speed when declining.

## Turning Signal :

Press down at left side to turn on the left turning signal. Press down at right side to turn on the right turning signal. (Figure 8)

## Headlight :

- By turning the key to [  ] to turn on the head light.(Figure 9)
- Turn the key back to ON, the headlight is off.



Figure 7

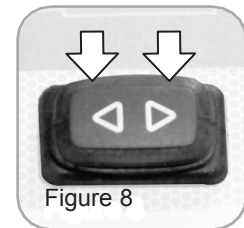

Figure 8

## Horn :

Press down the button to sound buzzer. (Refer Section 3-24 )

## Throttle :

- Pull the right throttle to move scooter forward. /Pull the left throttle to move scooter backward. This can be reversed if required by local dealer. (Figure 10)
- These are also your accelerator. The further you depress them, the faster you go.(Subject to the position of speed control)
- Releasing both left /right throttles automatically operates the brake to slow down and stop.

Brake light will be activated and have steady red light on for 5 seconds. (Figure 10)

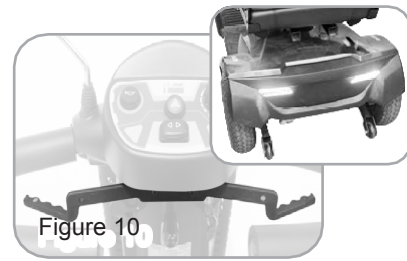
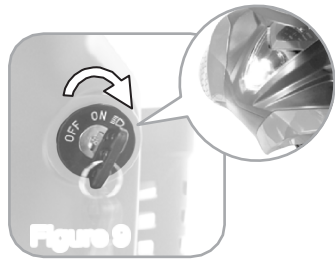

**Tiller angle adjustment :**

- Pull the tiller adjustment downwards to adjust tiller's angle and release to lock at a desired comfortable position. (Figure 12)

 Do not pull both right and left throttle at the same time, you might not able to control the scooter. Always ensure the scooter is switched off before getting on or off the scooter.

**Seat Swivel Adjustment :**

- Pull the swivel lever upwardsto rotate seat left and right. (Figure 13)

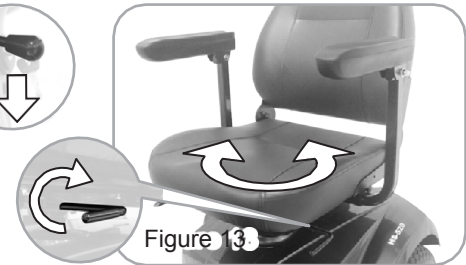
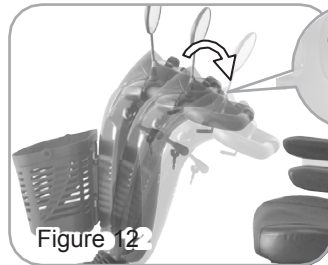

**Seat fore-aft Adjustment :**

- Set at a comfortable position by lifting leverforward to adjust the seat. (Figure 14)



**Armrest angle, height, and width adjustment :**

- **Angle :** rotate the screw as picture to adjust the most comfortable armrest angle. (Figure 15)
- **Width :** Loosen the thumbscrews as picture to adjust the width, tighten again to lock at a desired position. (Figure 16)
- Pull the armrest up when getting on or off the scooter.

 When driving the scooter, set the seat at foremost position to prevent tip over. Do not hangheavy goods on the armrests.

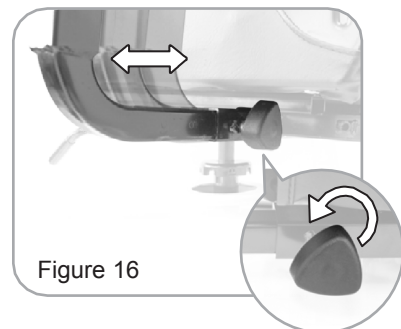
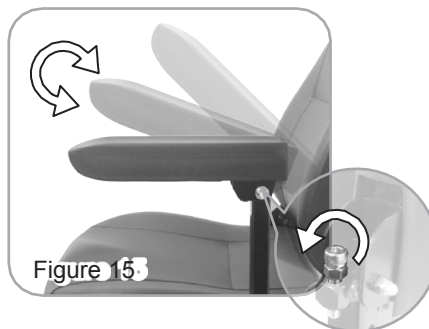

### 1. FREE-WHEELING (N-D LEVER)

- When lever is in Neutral (N) position, scooter can be moved manually without power. (Figure 17-2)
- When lever is in Drive (D) position, scooter can be driven. Normal position is D. (Figure 17-1)



Freewheel operation is only recommended on flat surfaces. Never leave your scooter on gradient with its motors disengaged.

When adjusting N-D lever, do not sit on the scooter. It's not able to drive the scooter when the lever is in Neutral. You must turn off the scooter first and switch to D lever, then turn on and drive scooter.



Figure 17

### 2. TIE-DOWN HOOKS

- To ensure safety during the transportation. There are four fixed hooks for fixing scooter on other vehicles.
- Make sure the scooter's N-D lever is in D position when transporting. (Figure 18)
- Do not sit on the scooter during transportation.

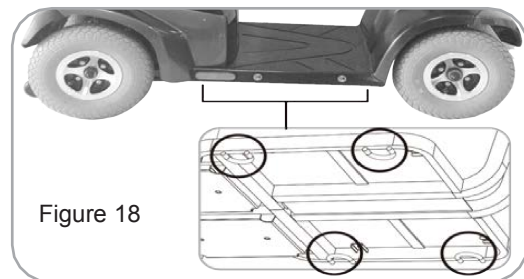

Figure 18

### 3. DISASSEMBLING YOUR SCOOTER

#### Disassembling seat :

- By lifting lever to remove seat upwards. (Figure 19)

#### Rear Compartment cover :

- Open the compartment cover upwards according to the example. (Figure 20)

#### Disassembling front basket :

- Lift the front basket upwards. (Figure 21)



Do not turn on the scooter when disassemble/assemble the scooter, and make sure the scooter is in D position. Do not modify or change the scooter with non-authorized parts or accessories.



Figure 19

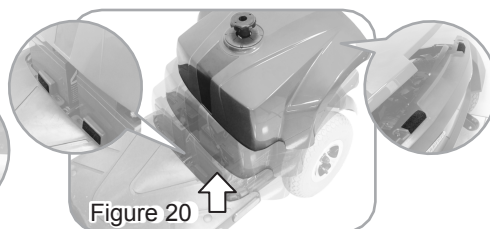

Figure 20

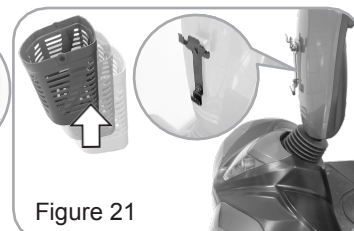
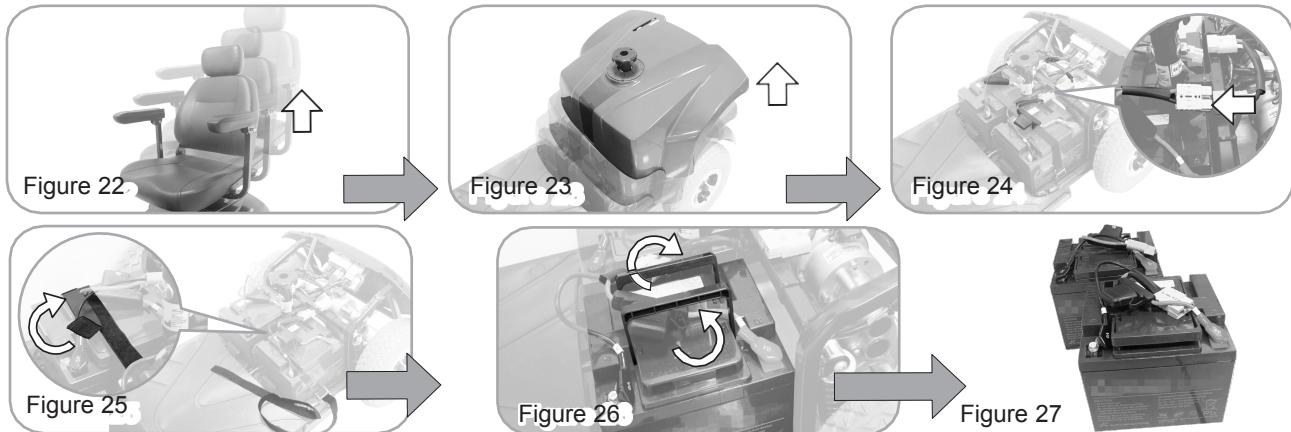

Figure 21

## 4. DISASSEMBLING BATTERIES

Release the battery velcro straps and disconnect the battery connectors to remove the batteries. (Figure 22~27)



Batteries are heavy, be careful when removing the batteries.

Do not connect battery terminal [+] [-] with any metals to avoid danger. Connect the red terminal to red, blue terminal to blue.

When replacing the batteries remove the screws and connectors in sequence and tighten each component back.

Maintenance & repair must only be carried out by a competent engineer or authorized dealer.

## BATTERY GAUGE AND CHARGER

### 1. BATTERY GAUGE

There is a meter shows batteries capacity status

- When battery gauge light trends to F, it indicates sufficient power capacity.
- When battery gauge light trends to E, it indicates insufficient power capacity.



Check battery capacity before driving. Recharge the battery immediately when the red light is flashing as the remaining power can only keep scooter going for buffering 3km or less

## 2. OPERATING THE CHARGER

**Batteries must be charged before using the scooter for the first time and should be recharged after each day use. You will need the scooter and the battery charger.**



Each country has their own AC power cord. The charging procedure may be different from below. If you require more details, please contact your authorized dealer. Make sure power switch is in OFF position and free-wheeling lever is in "D" position. Do not use extension cord to connect the charger. Do not use other brand charger to charge the scooter.

1. Open the charging socket cover (A) and insert the output connector (C) of the charger (D) into the socket (B), then plug the AC end of the cable into a 100-240V electrical outlet.
2. Please check if the Power Light (E) turns Yellow along with the status of the Indicator (F).

3. Charger Indicator status (F)
  - Rapidly Blinks Red = Error
  - Flashes Red = Standby
  - Steady Red = Charging
  - Steady Green = Fully Charged

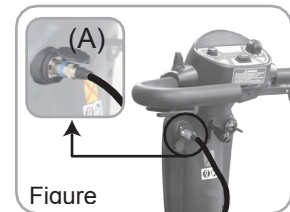

4. Please follow the instructions closely for your own safety. When fully charged, please unplug the charger in reverse order of Step 1.
5. Troubleshooting the charger:
  - If the Power Light (E) is off, please check if the connection is secure.
  - If the Indicator (F) is off, check if the connection is secure, otherwise the battery may be defective.
  - If the Steady Red light doesn't turn Green, please remove the defective battery as it can't be charged.
  - If the Steady Red light turns Green immediately, the battery may be fully charged, otherwise please remove defective battery.



- Please unplug the charger after the battery is fully charged to prevent slow discharge of electricity.
- Both ends of the charger must remain clean and dry. Do not connect to extension cords.
- Please avoid touching the charger as it heats up when charging to prevent burns.
- Use the Indicator (F) as the main point of reference, with the Power light (E) as secondary, to check if the battery is fully charged.
- Please do not charge non-stop over 15 hours.

Please note that the range of your mobility scooter depends on the rate at which the batteries discharge. This will depend on many circumstances, such as ambient temperature, road surface condition, tire pressure, driver's weight, driving environment (inclines, etc.) and your system usage. lighting, if applicable. We recommend testing your local route with a family member to ensure a safe journey.

## 1. INFORMATION FOR BATTERY & CHARGER

### Battery :

- Only be used for 12V lead-acid battery, not used for other type of battery or other voltage.
- Do not turn the key on while scooter is in charging.
- Charge the batteries after each trip. Only use the battery charger (under 5Amps) supplied with your scooter.
- If the scooter is not used for some time batteries must be recharged once every three months at least. Make sure that batteries are fully charged, and on returning, charge them again before using scooter.
- Batteries will only give maximum performance after scooter has been used. And batteries have been recharged up to 10 times.
- Do not switch off, unplug or interrupt the recharge cycle until the charging cycle has completed. (charger indicator turns green)
- The minimum time needed to recharge will vary up to 15hrs which depends on the depletion of the batteries. Excessive or short period charging will be detrimental to battery life.
- Please charge the scooter in 0°C ~ 40°C, out of this range might affect the performance of the charger and battery.
- For longest life, your batteries should be recharged regularly. Please recharge the batteries before they run down to 20%.

### Charger :

- Do not leave charger plugged into your scooter with charger switched off as this may discharge your batteries.
- Inspect the battery charger before each use, make sure connectors are dry and clean. Do not attempt to use an extension cord to plug in your battery charger.
- Be aware that the battery charger case may become hot during charging. Please avoid skin contact.



- \*The battery charger is equipped with cooling fan. If the fan does not appear to be working correctly, please turn off the charger immediately as it may be overheated. Please contact your authorized scooter dealer.
- \*Use the battery charger in a well-ventilated area. Do not smoke as explosive gases may be generated while charging the batteries.
- \*Any battery faults due to unauthorized maintenance, dismantle, misuse or accidental damage is not covered by the manufacturer's warranty.



# CARE AND MAINTENANCE

## 1. DAILY CHECK

Please always check your scooter before you start your every journey.

Check point	Inspection	What to do if the inspection is failed
N-D lever	Check for correct function	Contact your dealer.
Horn	Check for correct function	Contact your dealer.
Throttles	Pull the wigwag to test the scooter movement	Contact your dealer.
Electro-mechanical brake and Emergency hand brake	Pull the wigwag a little bit and release it to test if brakeworks. If your scooter comes with emergency handbrake, please check it as well.	Contact your dealer.
Battery Gauge	Check if the battery gauge is displayed and whether it is at low power.	<ul style="list-style-type: none"> <li>·Contact your dealer if battery gauge is not working.</li> <li>·Recharge the battery immediately if low</li> </ul>
Rear mirror (s)	Check if the parts are clean and firmly tighten to the scooter and do not wobble.	<ul style="list-style-type: none"> <li>·Clean up the dirt by damp cloth.</li> <li>·Tighten the screw or clamping stem that holds the mirror(s)</li> </ul>
Lighting	Check if all lights, such as head lights, rear lights, and turn signal are functioning correctly.	Contact your dealer.

## 2. WEEKLY CHECK

Check point	Inspection	What to do if the inspection is failed
Speed Dial Knob	Check for correct function	Contact your dealer.
Armrests	Check if the parts are clean and firmly tighten to the scooter and do not wobble. Tighten the screw knob that holds the armrest.	Contact your dealer.
Wheels/Tires	Inflate the tire to the correct pressure and check that 1. Drive wheels rotate without wobbling. 2. Tire tread depth is not less than 0.5mm. 3. No foreign objects in tires.	Contact your dealer.
Motor	Check for correct function	Contact your dealer.

Battery Charger	Check if the charger is functioning correctly and the batteries are charged.	Contact your dealer.
-----------------	--	----------------------

### 3. MONTHLY CHECK

Check point	Inspection	What to do if the inspection is failed
Seat / Upholstery	Check for movement and if it's worn	Contact your dealer.
Electronics	Check if all the battery cables and connectors are firmly tightened to the scooter	Contact your dealer.

### 4. CLEANING YOUR SCOOTER

Do not use any abrasive or scouring liquids for cleaning. Only use a damp cloth and gentle detergent.

Do not use hose pipe or splash water directly onto the scooter as this may cause damage to electronics.

### 5. MAINTENANCE

User should inspect the scooter regularly to keep scooter in good running order.

Check if the electrical cable connectors are fully connected.

All maintenance and repair of scooter should be done by an authorized dealer.

#### Seat Upholstery :

Only use damp cloth and a little soap to wipe the seat. Do not use abrasive cleaners as this will damage the seat.

#### Storage :

Please store the scooter in a dry location. If store the scooter in long time, please disconnect the battery terminals.

Do not store your scooter where it will be exposed to source of direct heat, damp, oil, acid, alkaline, or where Ozone could be possibly generated. All of the above will minimize scooter / tire cycle and shorten its lifetime.

#### Tire :

User should inspect the tires frequently for damage, the presence of foreign bodies, unusual wear and sufficient tread depth. If replacement tires are needed, please contact the nearest dealer.

**The following areas require periodic inspection :**

Tire pressure between  
35-40 psi Tread depth  
drops below 0.5 mm

**Recommended range of storage,**

Temperature : -30 c ~ +50 c, Humidity : 25% ~ 85%

**Follow these easy steps to replace the tire :**

1. Turn off the scooter and remove the key. Make sure the lever is in D position before you lift the scooter.
2. Use an ratchet and socket to remove the drive wheel screw from the centre hub of the wheel. Pull the wheel off of the axle.
3. Separate the tire from the rim.
4. Remove the old tire and replace it with a new tire.
5. Slide the wheel back onto the shaft.

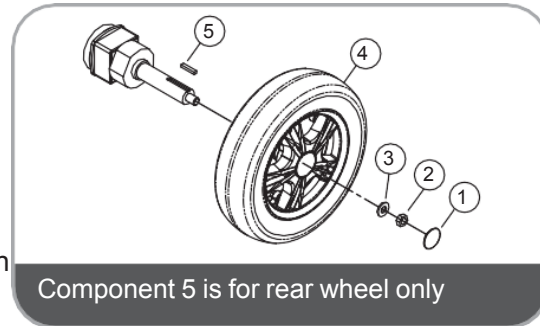

6. Install the drive wheel nut into the centre hub and verify the key is lined up with axle and wheel, then tighten to secure it in place. (Torque 300±30kgf-cm)

**All maintenance and repair of scooter should be done by an authorized dealer.**

## OTHER INFORMATION

### 1. RECYCLING & DISPOSAL

The equipment wrapping is potentially recyclable.

The metal parts are used for scrap metal recycling. The plastic parts are used for plastic recycling.

Electric components and printed circuit boards are disposed of as electronic scrap. Exhausted or damaged batteries can be returned to your medical equipment supplier. Disposal must be carried out in accordance with the respective national legal provisions. Ask your city or district council for details of the local waste management companies.

### 2. SERVICE LIFE

We estimate a service life of five years for this product, provided it is used in strict accordance with the intended use as set out in this document and all maintenance and service requirements are met. The estimated service can be exceeded if the product is carefully used and properly maintained, and provided technical and scientific advances do not result in technical limitations. The service life can also be considerably reduced by extreme or incorrect usage. The fact that we estimate a service life for this product does not constitute an additional warranty.

## TROUBLE SHOOTING

Here are some suggestions about solving problems you may have with your scooter. There is a self-diagnostic warning light on the control panel. To check the self-diagnostic warning light, turn on the key and count the number of blinks on the warning light.

### 1. SCOOTER WON'T MOVE WHEN KEY IS TURNED ON

Check point	Solution
Check if the power is off	Turn the power on.
Check if the N-D lever is in Neutral position	Switch to D (drive) position. Turn off the power and turn on again.
Check if the battery power is enough. (Battery gauge is under 25%)	Recharge the battery and then retest.
Check if the charger power cord is still plugged in scooter	Unplug the charger power cord.

## 2. ERREUR CODE

Flash	Description	Initial check points
1	Battery Low	The batteries are running low. Recharge the batteries.
2	Low Battery Fault	The batteries have run out of charge. Recharge the batteries. Check the battery and associated connections and wiring.
3	High Battery Fault	Battery voltage is too high. This may occur if overcharged and/or traveling down a long slope. If traveling down a slope, reduce your speed to minimize the amount of regenerative charging.
4	Current limit time-out controller overheat	The motor has been exceeding its maximum current rating for too long. The scooter may have stalled. Turn the controller off, leave for a few minutes and turn back on again. The motor may be faulty. Check the motor and associated connections and wiring.
5	Park Brake	Either a park brake release switch is active or the park brake is faulty. Check the park brake and associated connections and wiring. Ensure any associated switches are in their correct positions.
6	Drive Inhibit	Either a stop function is active or charger inhibits or "out of neutral at power up" condition has occurred. Release the stop condition (seat raised etc.) Disconnect the battery charger. Ensure the throttle is in Neutral when turning the controller on. The throttle may require re-calibration.
7	Speed Pot	The throttle, speed limit pot. SRW or their associated wiring may be faulty. Check the throttle and speed pot and associated connections and wiring.
8	Motor Voltage	The motor or its associated wiring is faulty. Check the motor and associated connections and wiring.
9	Other Error	The controller may have an internal fault. Check all connections and wiring.

## 3. OTHER PROBLEMS

TIRE : Low tire pressure: pump up tires to 35~40 psi.

Charger : During charging, light on charger doesn't change to green.

## TECHNICAL SPECIFICATION

Overall Length	1200 mm / 47.2"
Overall Width	640 mm / 25.2"
Overall Height	1155 mm / 45.5"
Front Wheels	290 mm / 11"
Rear Wheels	290 mm / 11"
Weight W/ Batteries	94 kg / 208 lbs
Max. Speed	13 kmph / 8 mph
Weight Capacity	136 kg / 300 lbs
Ground Clearance	65 mm / 2.6"
Grade Climbable	10 degree
Curb Climbable	70 mm / 2.8"
Turning Radius	1400 mm / 55.1"
Suspension	Front & Rear
Brake	Electro-Mechanical
Seat Type	Swivel Mid-Back W/ Headrest& Seat Sliding Mechanism
Seat Width	465 mm / 18.3"
Motor Size	700W, 4500 r.p.m
Battery Size	(2) 12V. 50Ah
Weight of Battery	30.5 kg / 67.2 lbs
Travel Range	40 km / 23 Miles
Battery Charger	5A Off Board

# MOVO WARRANTY

Movo products are designed to deliver an excellent performance and are high quality. For any warranty claim on an item deemed to be defective by both parties, Movo will, at its discretion, replace, repair or refund the defective item. The warranty begins upon receipt of the product by the retailer. Any damage or defect caused by misuse of the product is not covered by the warranty.

- Frame: two-year limited warranty.
- Controller: One year limited warranty.
- Electronic components (including motor gearbox) and charger: One-year limited warranty.

## **Excluded From Warranty**

- Engine brushes
- Tires
- Armrest
- Seat cushions
- Fuses and bulbs
- Bar cover (lining)
- Front and rear linings
- Lithium batteries
- Batteries and consumables



[info@moevolution.com](mailto:info@moevolution.com)  
Tél.: [1-888-480-MOVO](tel:1-888-480-MOVO) (6686)

**Granby, Québec**  
Canada